

NOTE:  
BENT FROM 720mm LONG x 16mm DIA. AISI 1020 ROD

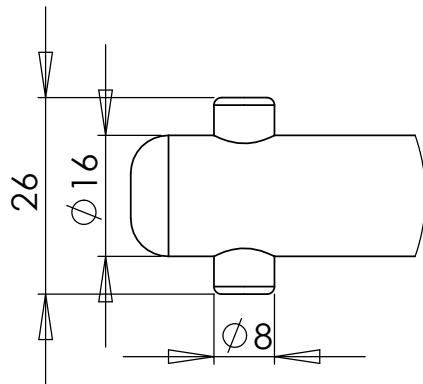

DETAIL C  
SCALE 1 : 1

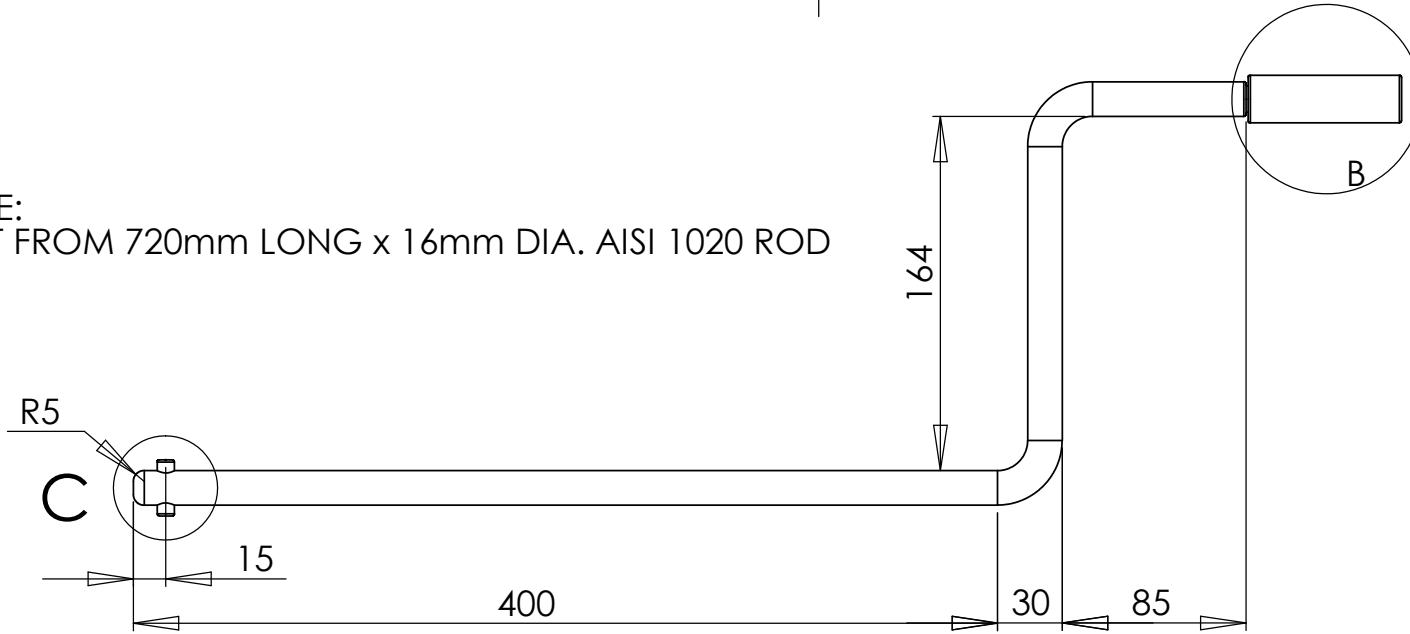
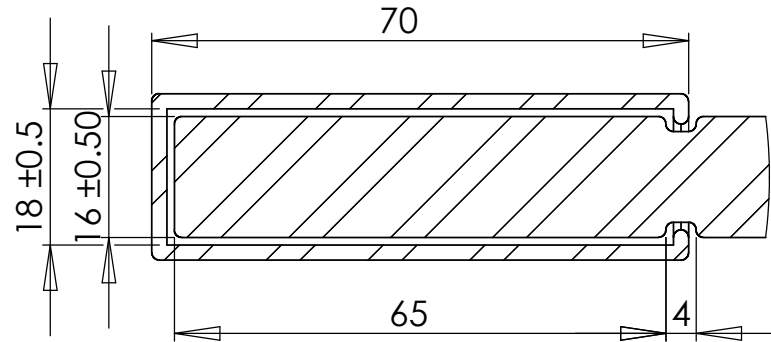

DETAIL B  
SCALE 1 : 1  
OPTIONAL SLIPPING HANDLE

UNLESS OTHERWISE SPECIFIED:  
DIMENSIONS ARE IN MM  
SURFACE FINISH: RAW  
TOLERANCES: N/A  
LINEAR: N/A  
ANGULAR: N/A

PROPRIETARY AND CONFIDENTIAL

THE INFORMATION CONTAINED IN THIS  
DRAWING IS THE SOLE PROPERTY OF  
ADVANCED BIOREFINERY INC (ABRI). ANY  
REPRODUCTION IN PART OR AS A WHOLE  
WITHOUT WRITTEN PERMISSION OF  
ABRI IS PROHIBITED.

| NAME                  | SIGNATURE                       | DATE | TITLE:                 |
|-----------------------|---------------------------------|------|------------------------|
| DRAWN: W SEAN HUFFMAN |                                 |      | <b>LADA NIVA CRANK</b> |
| CHK'D:                |                                 |      |                        |
| APPV'D:               |                                 |      |                        |
| MFG:                  |                                 |      |                        |
| Q.A:                  |                                 |      |                        |
| FINISH:               | DEBUR AND BREAK SHARP EDGES     |      | DWG NO.                |
| MATERIAL:             | AISI 1020 UNLESS OTHERWISE SPEC |      | A4                     |

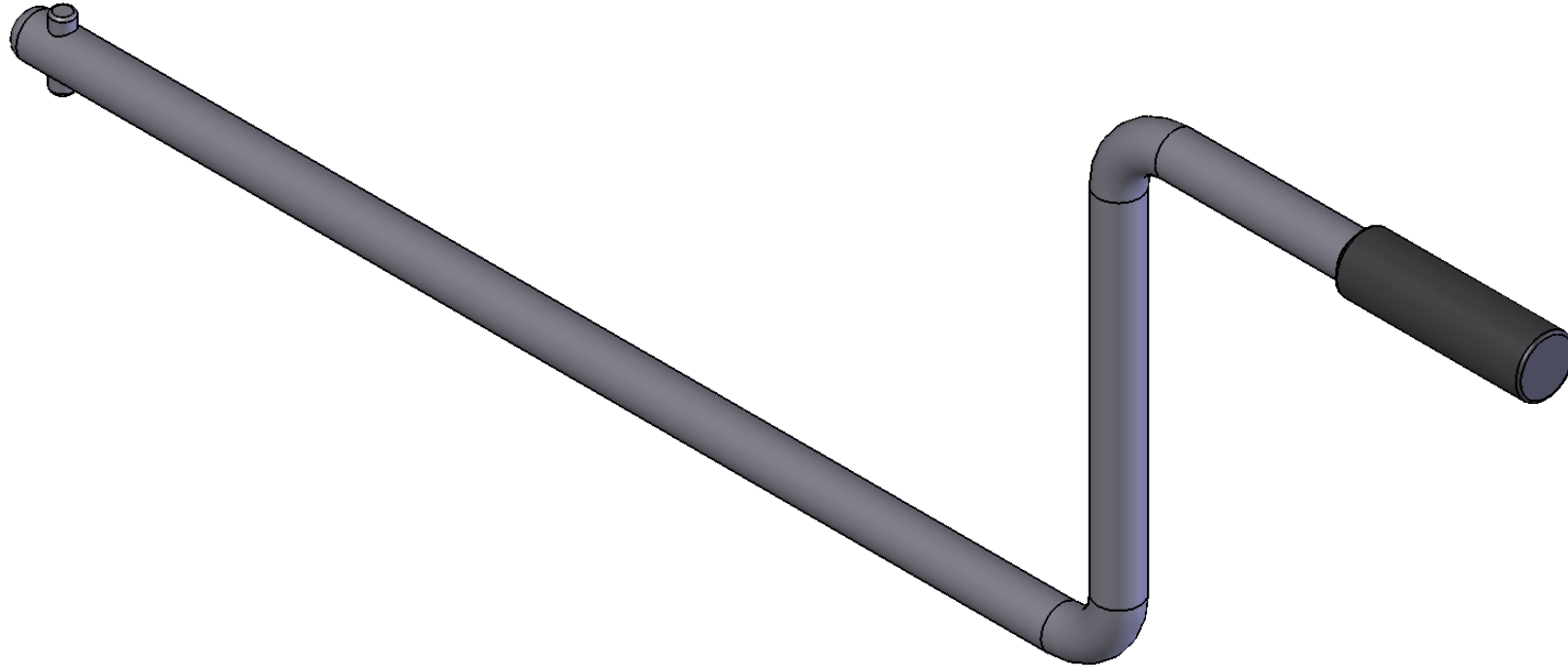

UNLESS OTHERWISE SPECIFIED:  
 DIMENSIONS ARE IN INCHES  
 SURFACE FINISH:  
 TOLERANCES:  
 LINEAR:  
 ANGULAR:

PROPRIETARY AND CONFIDENTIAL

THE INFORMATION CONTAINED IN THIS  
 DRAWING IS THE SOLE PROPERTY OF  
 ADVANCED BIOREFINERY INC (ABRI). ANY  
 REPRODUCTION IN PART OR AS A WHOLE  
 WITHOUT WRITTEN PERMISSION OF  
 ABRI IS PROHIBITED.

|           | NAME                       | SIGNATURE | DATE |
|-----------|----------------------------|-----------|------|
| DRAWN     |                            |           |      |
| CHK'D     |                            |           |      |
| APPV'D    |                            |           |      |
| MFG       |                            |           |      |
| Q.A       |                            |           |      |
| FINISH:   | DEBUR AND BREAK SHARPEDGES |           |      |
| MATERIAL: |                            |           |      |

|           |  |              |  |
|-----------|--|--------------|--|
| TITLE:    |  |              |  |
| DWG NO.   |  | lada crank   |  |
| SCALE:1:2 |  | SHEET 2 OF 2 |  |
|           |  | A4           |  |